



广州恒宽机械有限公司 Canton Hostandard Machinery CO., LTD

www.pocket-spring.com

Email: hostandard@hotmail.com

Mob: 0086-133-1411-7277

Skype: northland99

袋装弹簧床网生产线 HS-2PSM70-L-1SAM75 Pocket spring unit auto-transfer production line

QUOTE SHEET

Photo Details

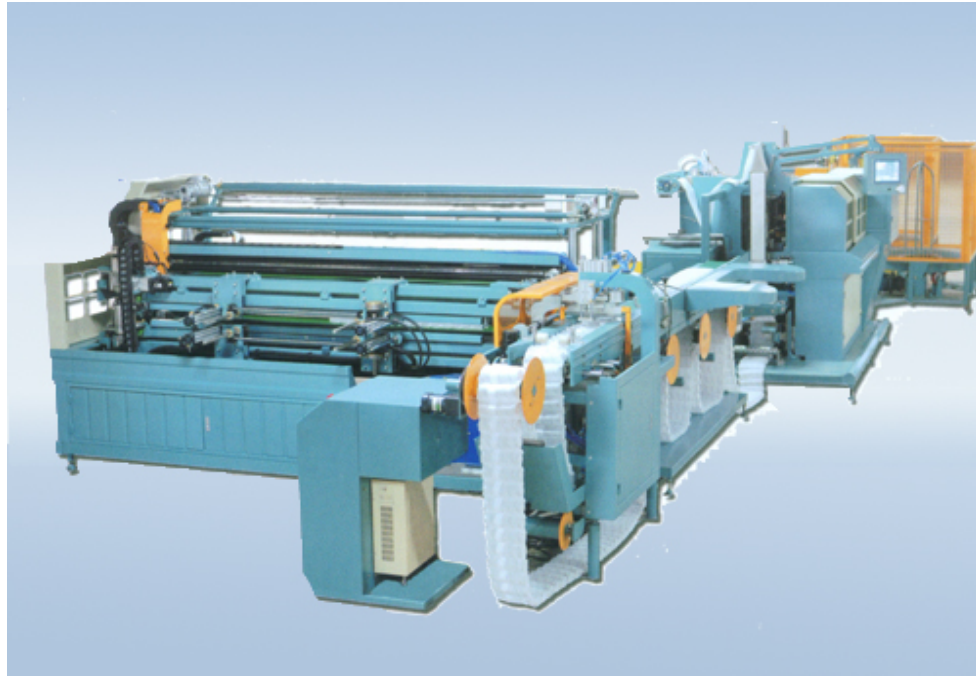

video weblink: <http://u.youku.com/northland99>

Technical Information:

Performance 生产效率

production capacity	生产速度(分钟/张)	6mins/unit
---------------------	------------	------------

Consumptive Material Specs 耗材参数

steel wire 钢丝	wire gauge	钢丝直径	1.6--2.2mm
	Iner Dia. of wire roll	钢丝卷内径	Min/最小350mm
	Outer Dia. of wire roll	钢丝卷外径	Max/最大1000mm
	Max weight of wire roll	钢丝卷重量	Max/最大800kg
Non-woven fabric (from coiler) 无纺布(弹簧生产机)	Fabric density	布料厚度	65~90g/m ²
	Fabric width	布料宽度	450-600mm
	Inner dia.of fabric roll	布辊内径	Min/最小60mm
	Outside diameter of fabric roll	布辊外径	Max/最大600mm
Hot melt glue 热熔胶	Fabric density	胶粒形状	pellent or pieces/粒状或片状
	Viscosity	黏度	125°C-6100cps 150°C-2300cps 175°C-1100cps
	Ring and Ball softening point	软化点	85±5°C
Non-woven fabric (for assembler) 无纺布(粘胶机)	Fabric density	布料厚度	65~90g/m ²
	Fabric width	布料宽度	300-2200mm
	Inner dia.of fabric roll	布辊内径	Min/最小65mm
	Outside diameter of fabric roll	布辊外径	Max/最大600mm

General Data 一般参数

Spring type	弹簧形状	Barrel(直筒型) Cylindrical(鼓形)
Mattress Width	床垫宽度	300-2150mm
Air consumption	气源需求量	Approx/约30m ³ /h
Air pressure	工作气压	0.6-0.7mpa
Power consumption in total	总功率	Approx/约 26KW
Power requirements	Voltage	3AC 380V
	Frequency	50/60Hz
	Input fuse	50A
	Cable section	4×16mm ²
Working temperature	工作温度	+5℃—+45℃
Weight	重量	Approx/约8000kg

Output Range 产品规格

		Wire Gauge	Spring Waist Diameter	Pocket spring height
		钢丝直径 (d)	弹簧中腰直径 (D)	弹簧入袋后高度 (H)
Standard/常规	A	φ1.6-φ2.1	φ55-φ70	80-140
	B	φ1.6-φ2.1	φ55-φ70	120-180
	C	φ1.6-φ2.1	φ60-φ75	80-140
	D	φ1.6-φ2.1	φ60-φ75	120-180
	E	φ1.6-φ2.1	φ60-φ75	140-200
Special/特殊	S1	φ1.3-φ1.6	φ45-φ55	70-120
	S2	φ1.3-φ1.6	φ45-φ55	120-180
	S3	φ1.2-φ1.4	φ40-φ45	120-180
	S4	φ1.6-φ2.1	φ50-φ60	180-230
	S5	φ1.6-φ2.1	φ60-φ70	180-230
	S6	φ1.6-φ2.1	φ50-φ60	220-260
	S7	φ1.6-φ2.1	φ60-φ70	220-260

Footprint 占用空间

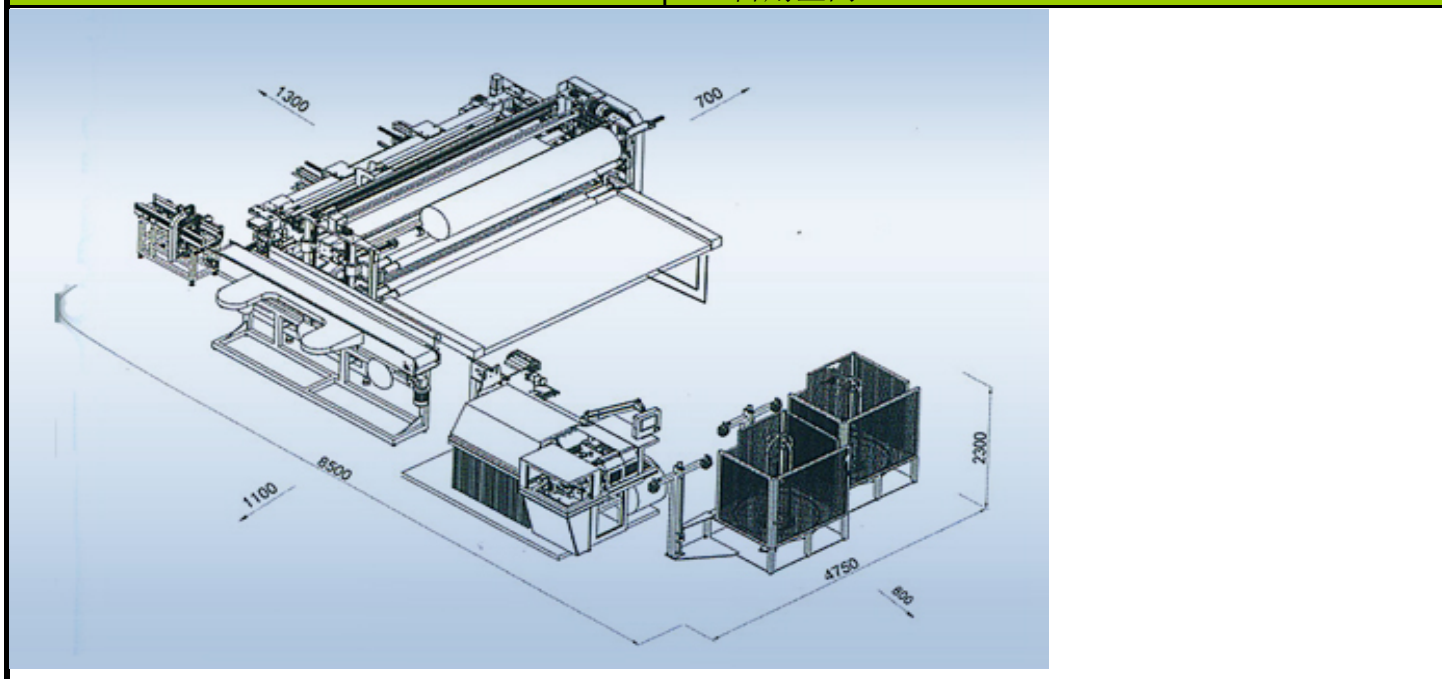

AFTER-SALE SERVICE 售后服务		PACKAGING INFO 包装信息	
installation:	new machine installation free	packing material:	wood or plywood
	expenditures of way and accommodation paid by customer.	package count:	
		Packing dimensions:	
warranty:	1 year	Volume:	
	free spare parts offered during warranty	gross weight:	
spare parts:	spare parts list offered.	net weight:	
ADDITIONAL COMMENTS&REMARK			
*Payment terms: T/T 30% deposit in advance, balance 70% 3 days before shipment.			
*Agent policy: in some countries or areas, you can ask our agent for efficient service.			